



360°



---

1	.....	1
3	.....	8
4	.....	11
5	.....	16
6	.....	18
7	.....	20

1.1

“ ” “ ” “ ” “ ” “ ” “ ” “ ”

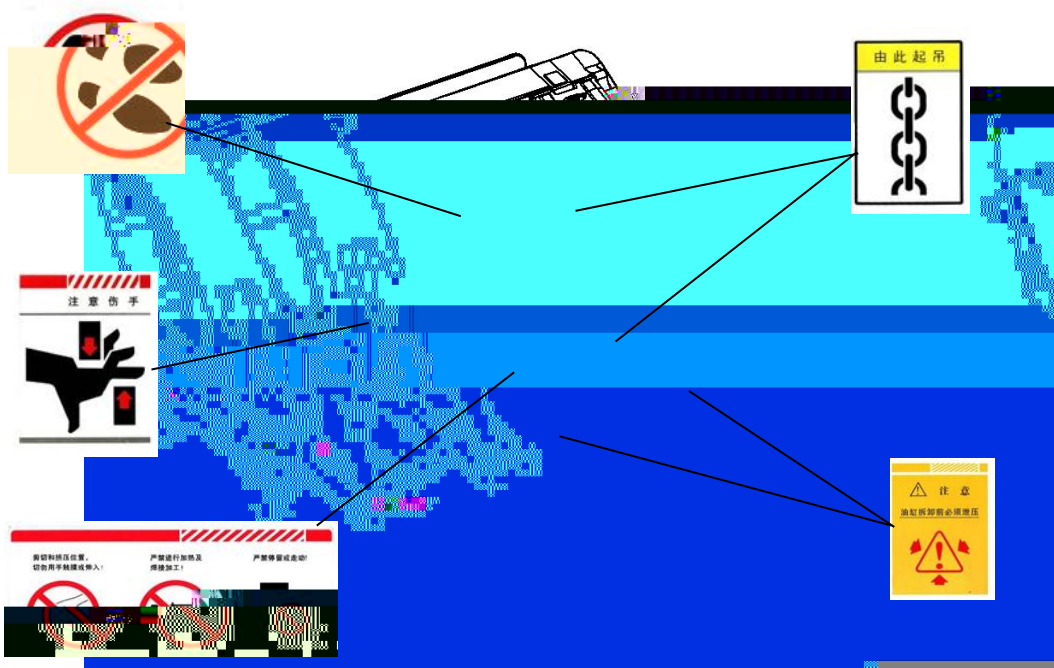

---

1.2

---

---

---

---

---                      -20 ~40    85    2000

1.3

1.3.1

1.3.1.1

- 
- 
- 
- 
- 

1.3.1.2

- 
- 
- 
- 
- 
- 
-



1. 3. 2



1. 3. 3

---

---

80

80

---

---

---

---

---

---

1. 3. 4

---

---

---

---

---

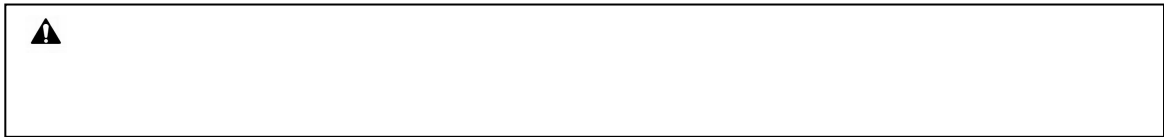

---

---



ISO4762 ISO4014 ISO4032

	8.8	10.9	12.9
M0	45Nm	66Nm	77Nm
M2	77Nm	115Nm	135Nm
M6	190Nm	280Nm	330Nm
M20	385Nm	550Nm	640Nm

---

---

#### 1.4

---

— —

— —

— —

2.1

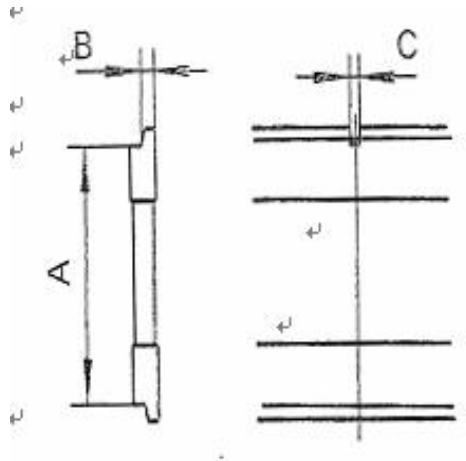

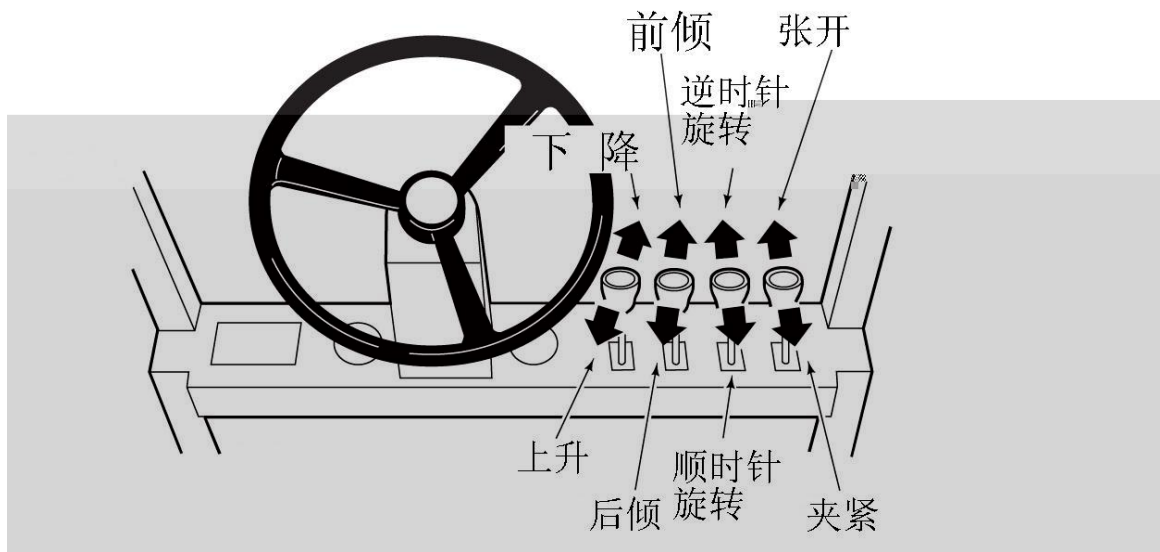

2.4

	Bar		L/m <sup>3</sup> n		
ZJ13H ZJ13/12/11/10R	140	160	19	26	38
ZJ22/25/27/33H	140	160	19	38	57
ZJ35/45R/ZJ38/46H	140	160	38	57	76



3

3.1

- 1、拆除包装，将属具吊起，垂直放置与托盘上。
- 2、拆除下钩。

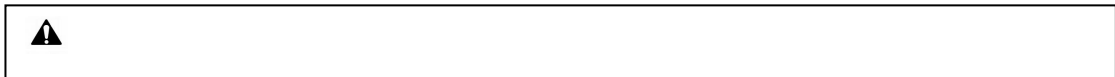
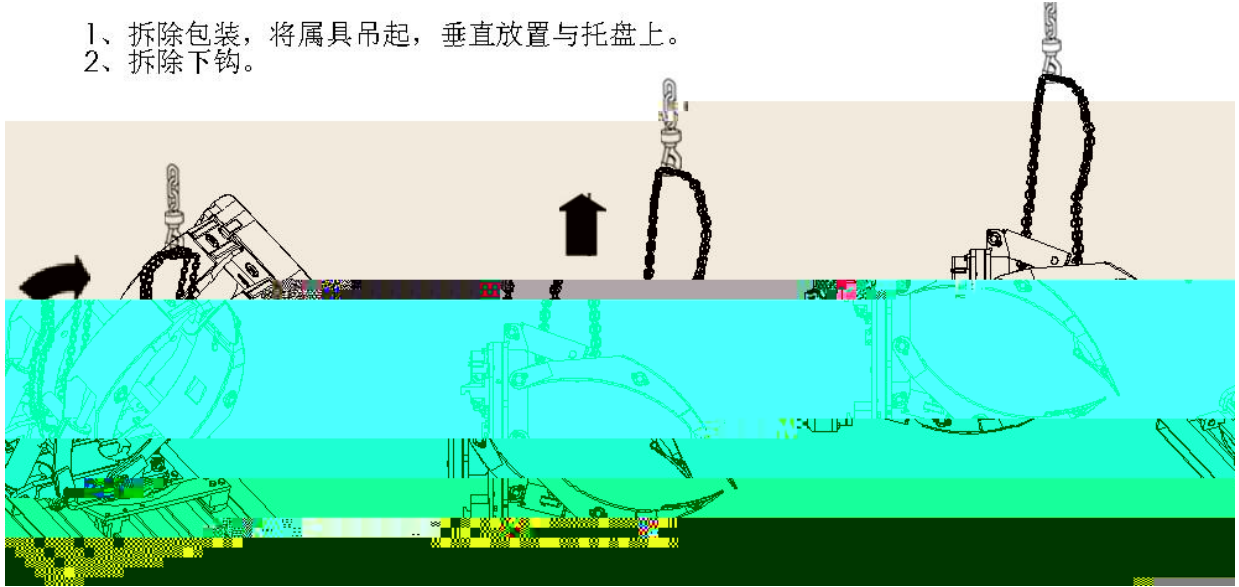

3.2

30

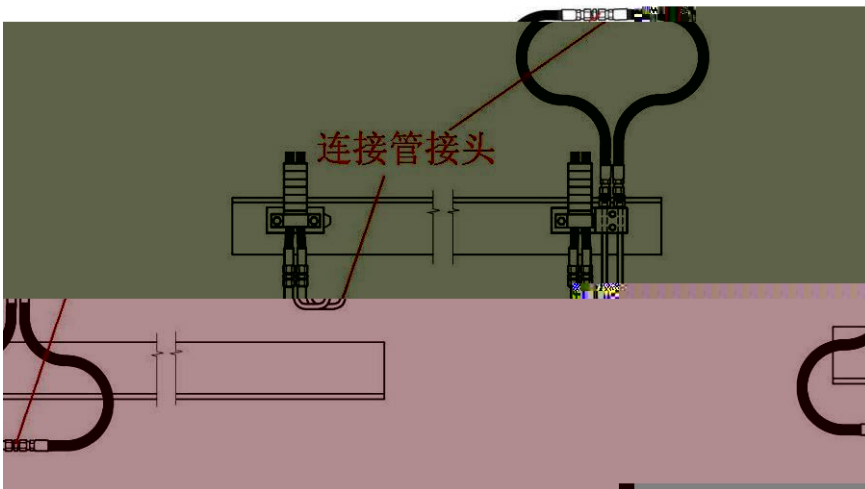

3.3

3.4

3.5

142 155N m

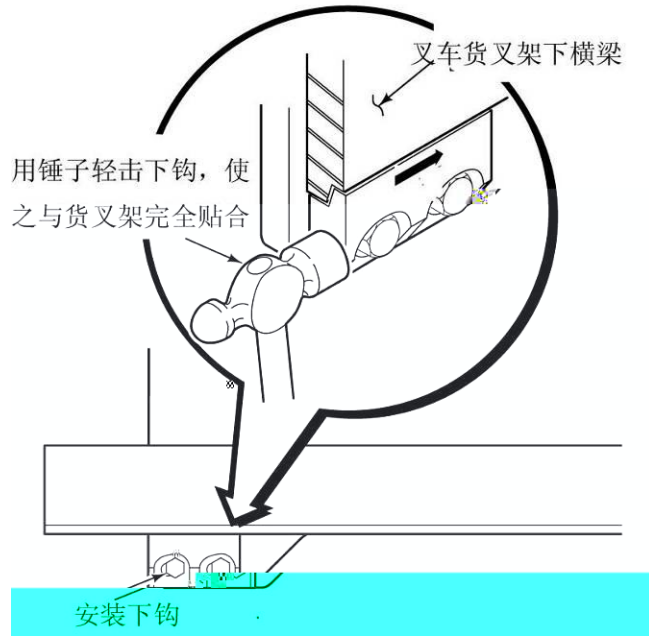

3.6

1.5mm

200

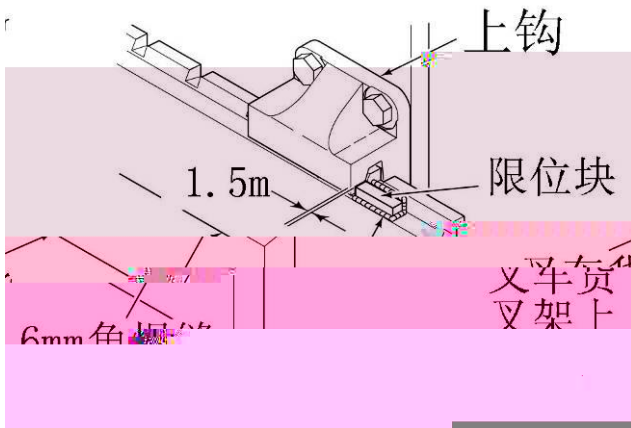

### 3.7

1



2

45°

3

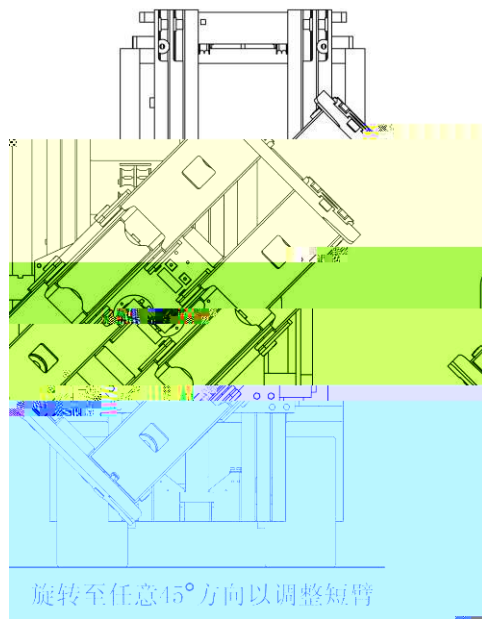

4

3



4

4.1

/

8cm

3~4°

30cm

4.2

---

**=ê**

;

4.3

4.3.1 m'

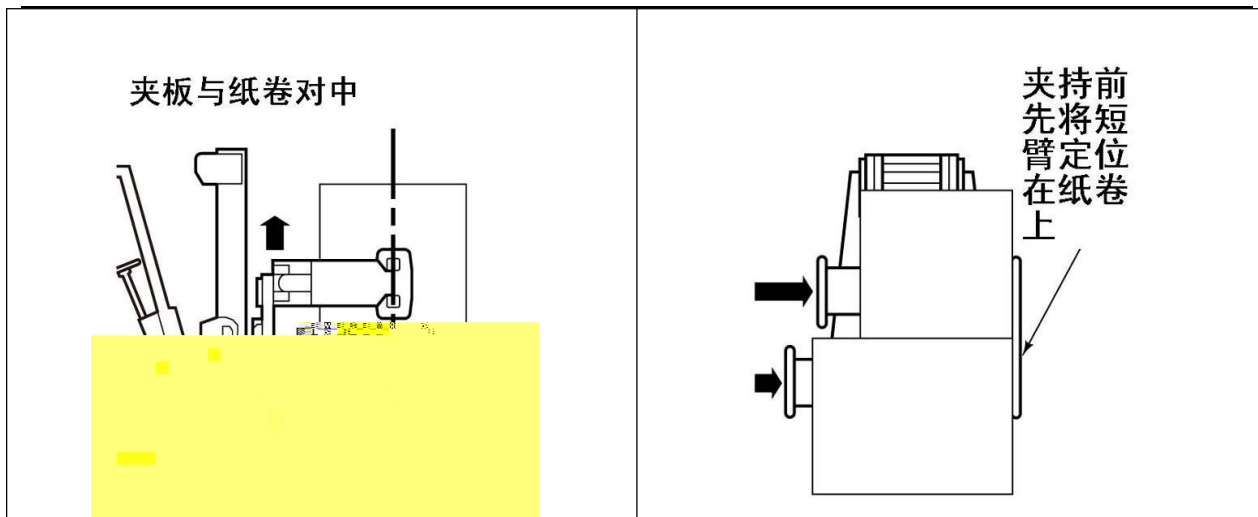

#### 4.4

##### 4.4.1

(1)

2

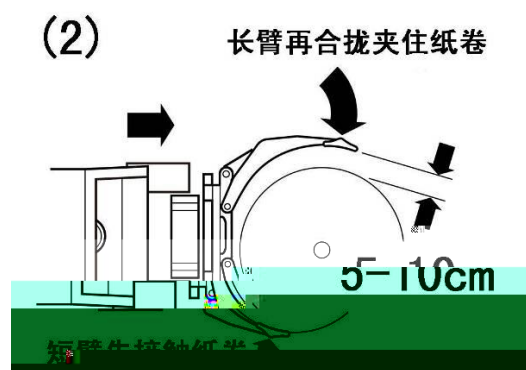
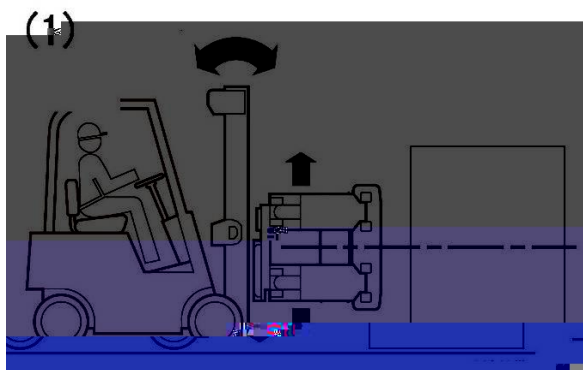

3

(3)

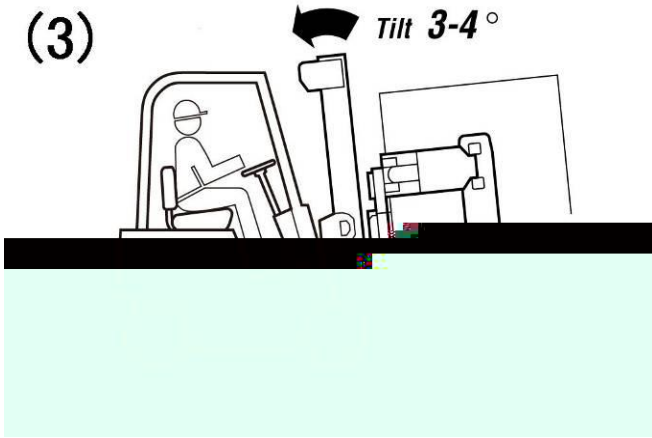

4

(4)

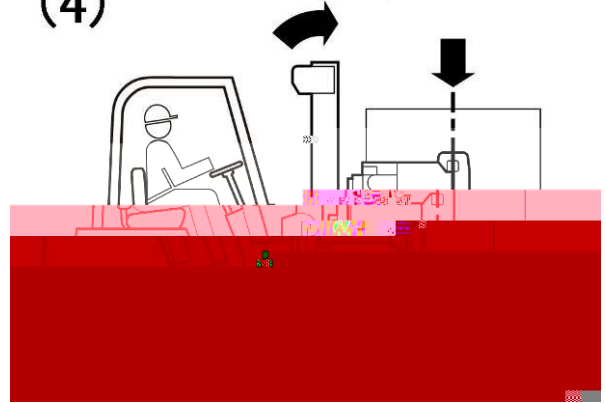

4.4.2

1

(1)

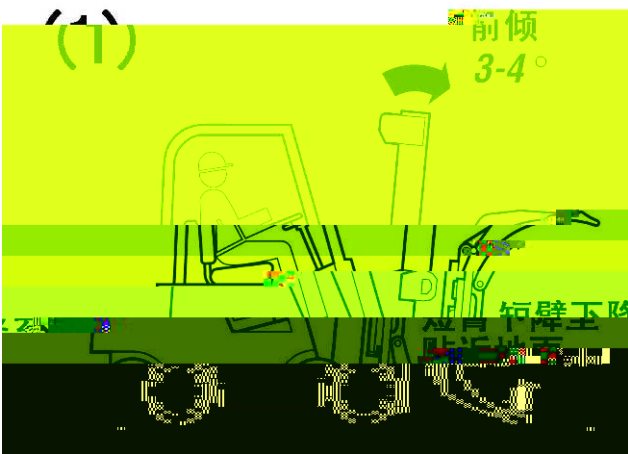

2

(2)

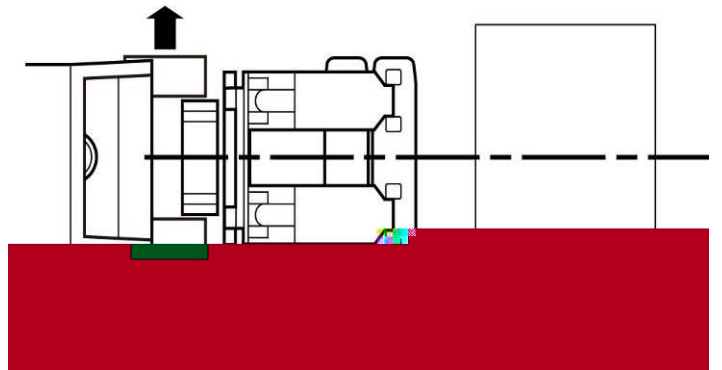

3

(3)

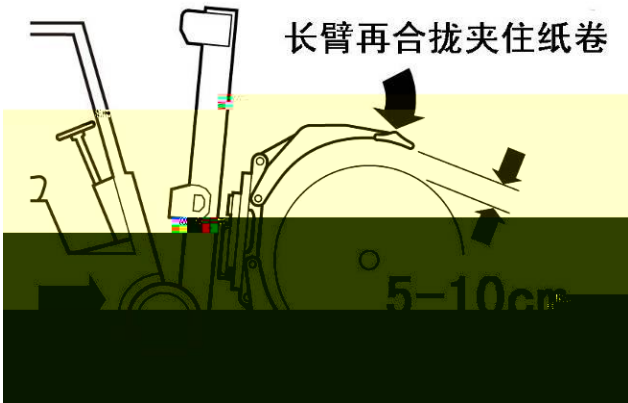

4

(4) 后倾 3-4°

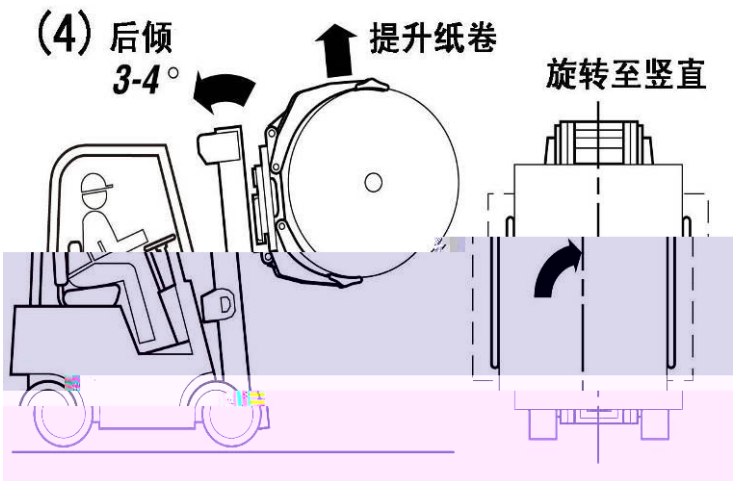

5

(5)

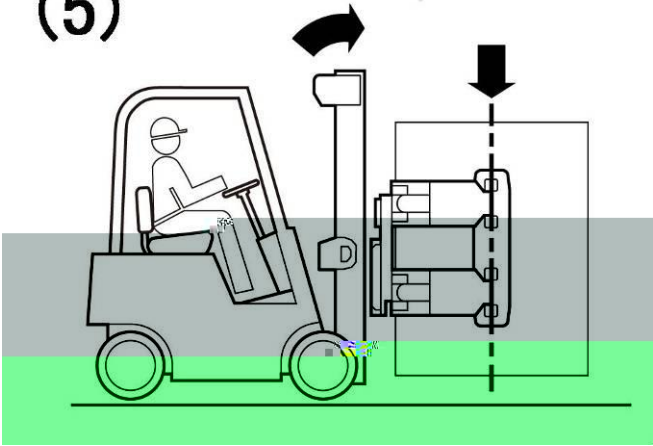

---

5

5.1 100

100

5.2 500

500

100

140N m

220N m

GL-5

SAE-85W/90

5.3 1000

1000

100 500

5.4 2000

2000

100 500 1000

---

5. 5

---

6

6.1

---

2.4

---

---

6.2

---

6.3

---

---

---

---

---

---

---

170bar

6.4

---

---

---

6.5

---

---

---

---

---

6.6

6.7

6.8

0.1mm—

0.3mm—

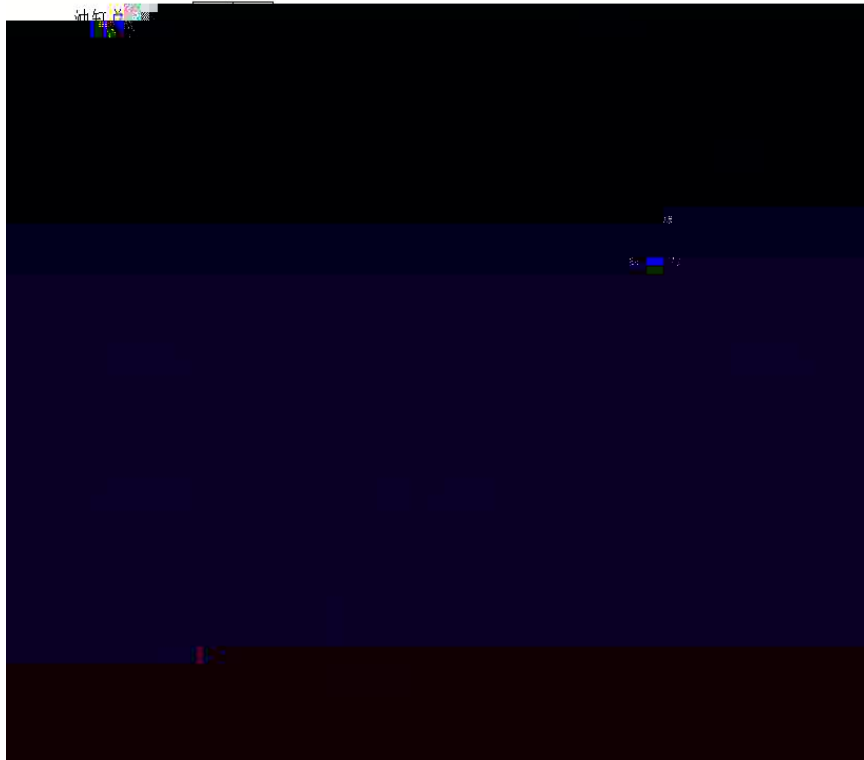

"

"

7.1

7.1.1

1

2            4000

12                            2000

"                            "

7.2

7.2.1

7.2.2

7.2.3

7.3

7.3.1

7.3.2

7. 3. 3

7. 3. 4

7. 4

/

0556- 5345329/5228123

2025 8 28

