





**Contents**

- ..... **1**
- ..... **6**
- ..... **8**
- ..... **14**
- ..... **18**
- ..... **20**
- ..... **23**



□

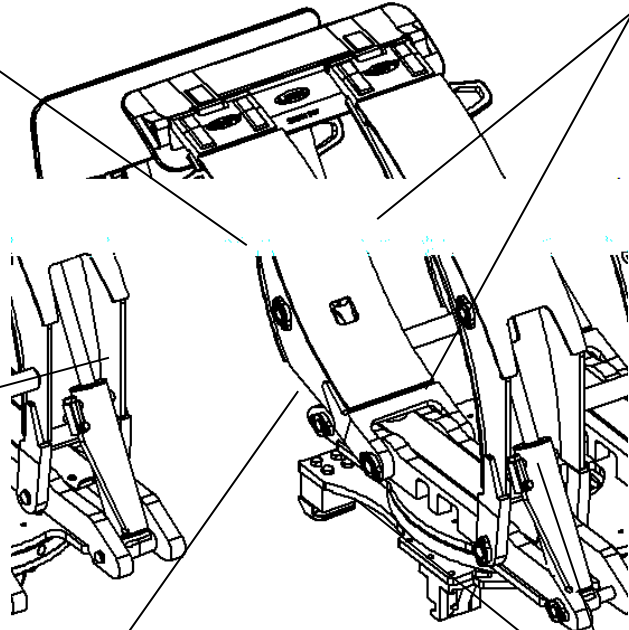
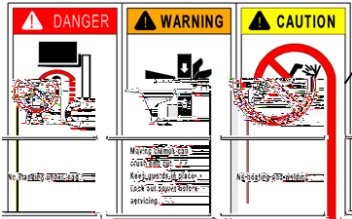
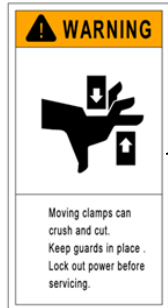
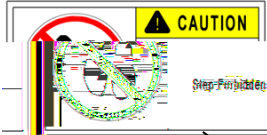

□

■

■

■

■

■

□

**WARNING!**

■ T





Roll Clamp User Manual

---

<input type="checkbox"/>	<input type="checkbox"/>	<input type="checkbox"/>
<input type="checkbox"/>	<input type="checkbox"/>	<input type="checkbox"/>
<input type="checkbox"/>	<input type="checkbox"/>	<input type="checkbox"/>
<input type="checkbox"/>	<input type="checkbox"/>	<input type="checkbox"/>
<input type="checkbox"/>	<input type="checkbox"/>	<input type="checkbox"/>

---

■

■

■

■

■



Model	Pressure value bar		Flow value L/min		
			Rotary motion		
	min	max	min	recommend	max
ZJ10R/11R/12R/13R/13H	140	160	19	26	38
ZJ22H/25H/27H/33H	140	160	19	38	57
ZJ38H/35R/42H/45R	140	160	38	57	76

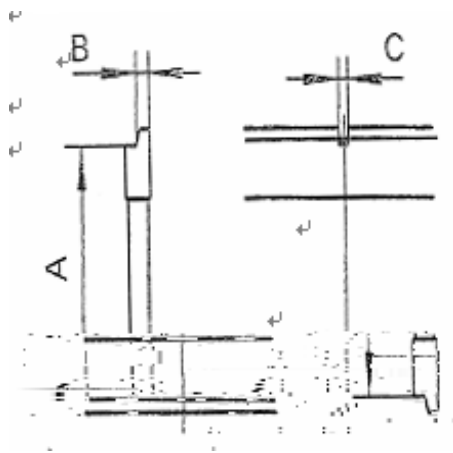

Installation level	A		B		C	
	min	max	min	max	min	max
	380	381	15	16	15.2	16.8
	474.5	476	20.5	21.5	18.2	19.8
	595.5	597	24.5	25.5	18.2	19.8

Figure 1

1. remove of the packaging, then lifting the truck attachments and place on the tray
2. demolition the under foot



叉车货叉架下横梁

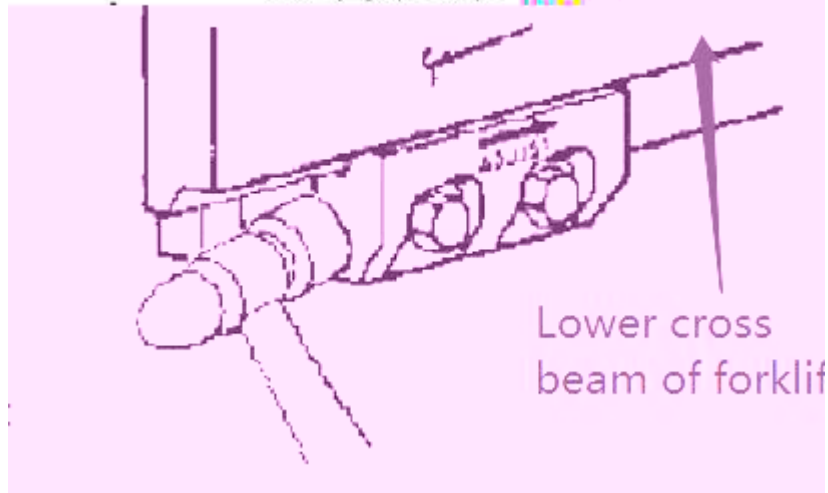

# Roll Clamp User Manual

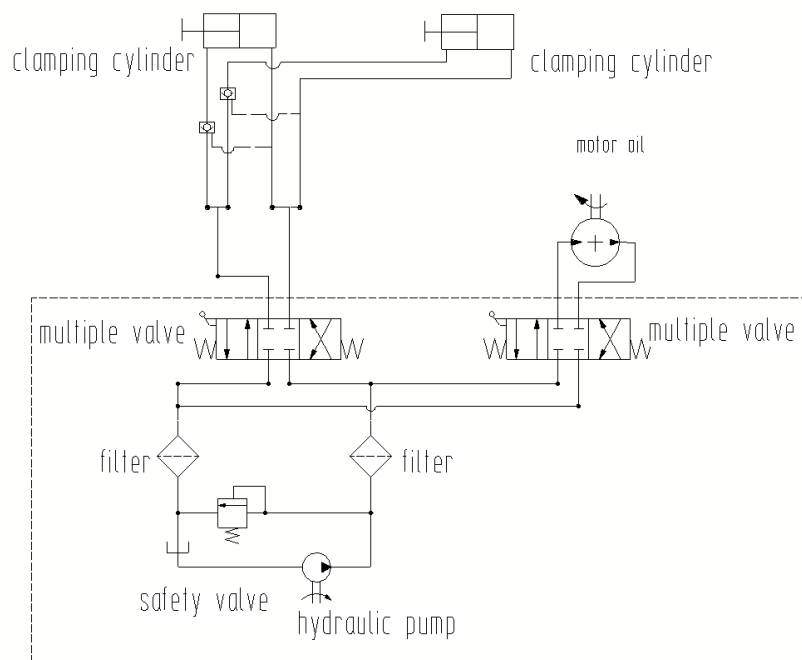

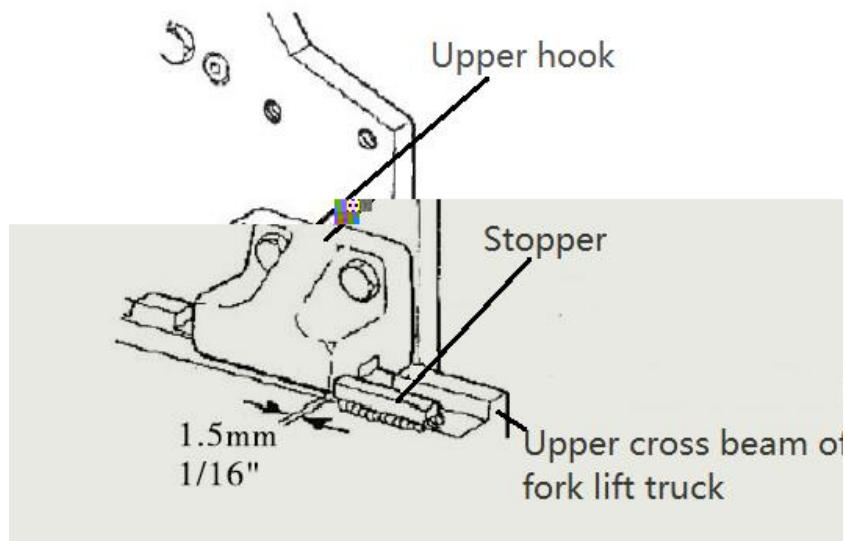

Upper hook Stopper Upper crossbeam of the forklift carriage

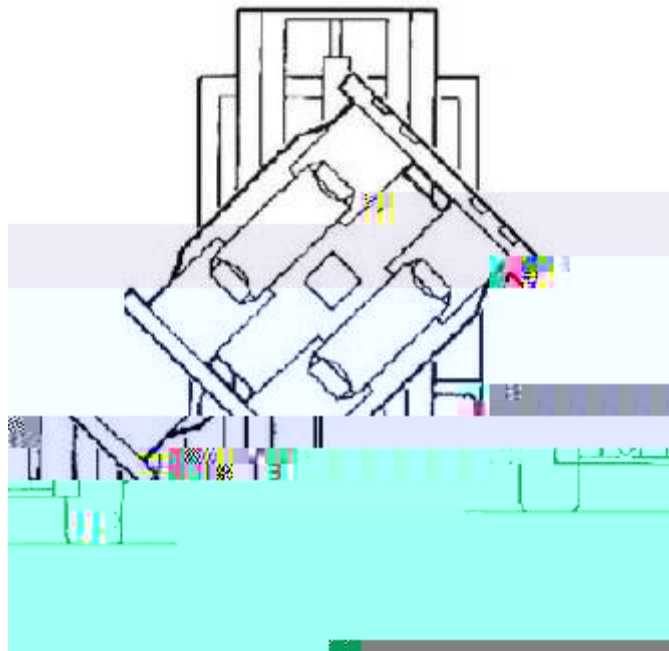

Turn to any point of 45° to adjust the short arm

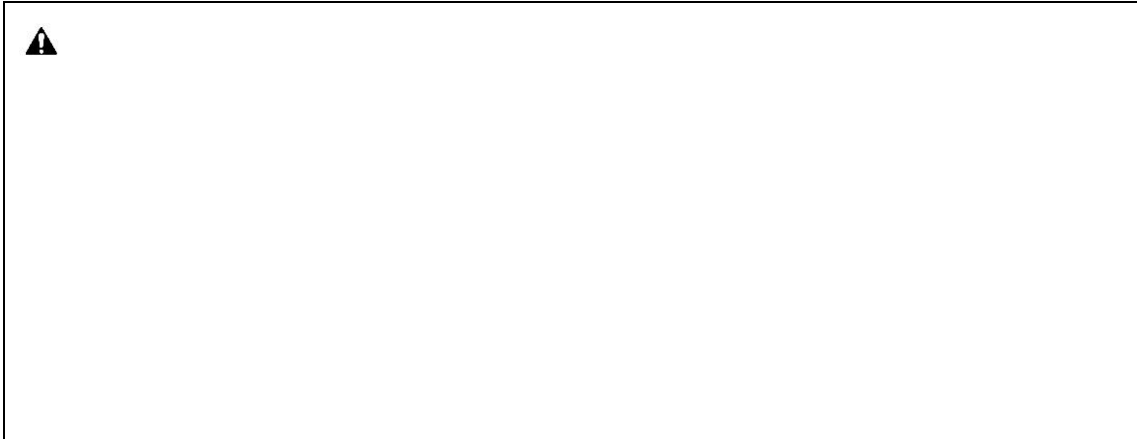

--	--	--

Roll Clamp User Manual

---

## Roll Clamp User Manual

---

## Roll Clamp User Manual

---

## Roll Clamp User Manual

---

## Roll Clamp User Manual

---

## Roll Clamp User Manual

---

## Roll Clamp User Manual

---

## Roll Clamp User Manual

---

## Roll Clamp User Manual

---

## Roll Clamp User Manual

---

## Roll Clamp User Manual

---

## Roll Clamp User Manual

---